

# Thermoplastic Polyurethane Elastomers (TPU)

Elastollan® –  
Processing  
Recommendations

Technical Information

 **BASF**

The Chemical Company

# Contents

## General Recommendations

Storage	4
Drying	5
Colouring	6
Additives	6
Use of Regrind	6
Post-treatment	7
Health & Safety at Work	8
Disposal	8

## Processing Injection Moulding

Machine Design	9
Processing Parameters	10
Mould Design	12
Shrinkage	14
Inserts	14
Special Processing Methods	15
Trouble Shooting Guidelines	15

## Processing Extrusion

Machine Design	16
Processing Parameters	17
Die Design	18
Cooling and Calibration	19
Extrusion Techniques	20
Special Processing Methods	22
Trouble Shooting Guidelines	22

## Finishing Procedures

Welding	23
Bonding	23
Surface Finishing	23

# Contents

## Machining

Machining Parameters	24
Drilling	24
Turning	25
Milling	25
Cutting	25
Grinding	25
Punching	25

## Quality Management

	26
--	----

## Index of Key Terms

	27
--	----

# General Recommendations

## Storage

Elastollan is the protected trade mark of our thermoplastic polyurethane elastomers (TPU). These materials are used for injection moulding, extrusion and blow moulding.

The following recommendations should be observed in the processing of Elastollan materials.

Elastollan grades are supplied uncoloured, in diced, cylindrical or lentil-shaped form. The materials are hygroscopic i.e. dry Elastollan, when exposed to the atmosphere will rapidly absorb moisture. Polyether-based Elastollan grades absorb more rapidly moisture than polyester-based grades.

Figures 1 and 2 show the rate of moisture absorption.

Storage in dry conditions, if possible at room temperature, is therefore recommended.

In order to prevent condensation, material stored in cool conditions should be brought to room temperature before opening the container.

Containers should be tightly closed after use. The granulate should be exposed to the surrounding air only for as long as absolutely essential. It is therefore important to cover the feed hopper of the processing machine. Drying is recommended if the container has been opened several times.

### Moisture absorption Polyester-TPU Hardness 80 Shore A – 64 Shore D

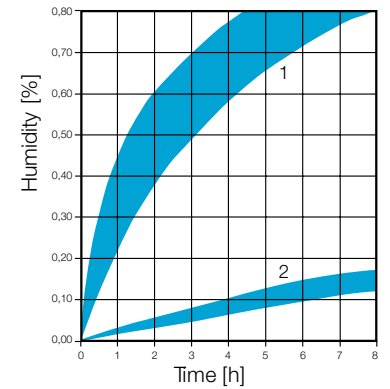

- 1 – Standard atmosphere 40°C/92% rel. hum.
- 2 – Standard atmosphere 23°C/50% rel. hum.

Fig. 1

### Moisture absorption Polyether-TPU Hardness 80 Shore A – 64 Shore D

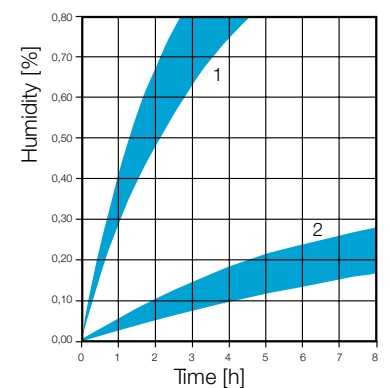

- 1 – Standard atmosphere 40°C/92% rel. hum.
- 2 – Standard atmosphere 23°C/50% rel. hum.

Fig. 2

# General Recommendations

## Drying

Excessive moisture content in the granulate can lead to processing problems and to a reduction in the quality of the finished part.

Foaming of the plasticized material or the formation of gas bubbles in the melt are indications that the moisture content is excessively high. Variations in output during extrusion processing are in many cases attributable to insufficient pre-drying.

In order to ensure optimal performance properties in the finished Elastollan parts, it is necessary that the material is dried before processing. **Water content of the granulate should not exceed 0.02%.**

Conventional circulating-air ovens, vacuum drying cabinets and dehumidified air dryers are suitable for this purpose. For recommended drying parameters see table 1.

When using circulating-air ovens, the layer of granulate should not exceed 4 cm in height. With dehumidified air dryers, the total available capacity may be utilized. After drying, the granulate should be immediately stored in dry containers which can be securely sealed.

**When colour masterbatches and additives are used, care must be taken to see that they are also dried.** Therefore it is better to pre-mix with the granulate before the drying process to make sure that the whole product is dried.

Drying recommendations			
Elastollan hardness	Drying time	Drying temperature	
		Circulating air	Dehumidified air
Shore A 78 to 90	2 to 3 hours	100 to 110°C	80 to 90°C
harder than Shore A 90	2 to 3 hours	100 to 120°C	90 to 120°C

Table 1

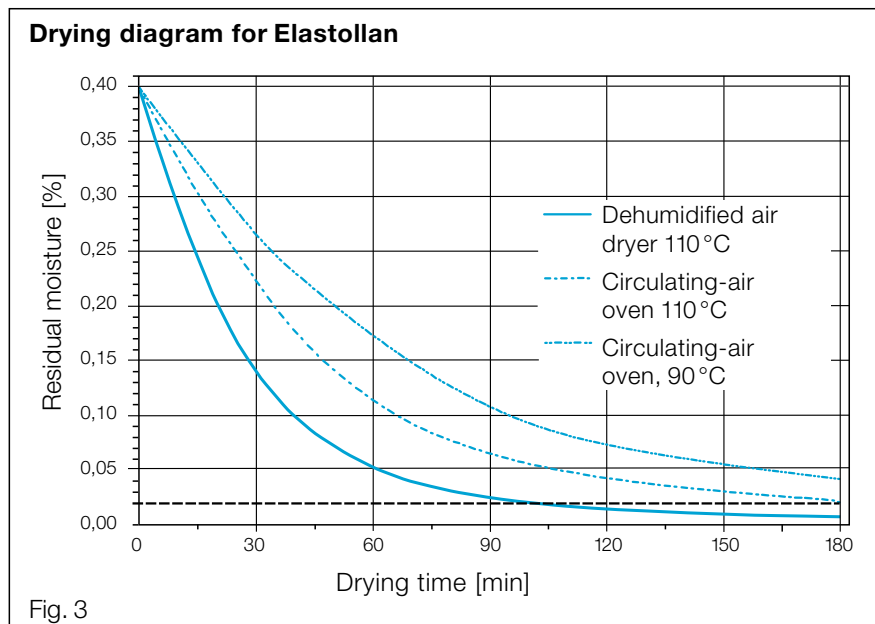

# General Recommendations

## Colouring

All grades in our Elastollan range can be coloured. Masterbatches based on TPU are most suitable for this purpose. The normal level of addition of colour masterbatch is 2%, however, Elastollan grades containing pre-included additives, e.g. flame retardant types, may require a high loading to achieve the full depth of colour.

There is a risk that non-Elastollan-based colour masterbatches will prove incompatible with Elastollan grades. Poor pigment dispersion and a lack of colouring strength, as well as poor surface finish and possible loss of quality may result.

## Additives

Various additives can be used to enhance the properties of Elastollan materials. Following additives supplied as Elastollan masterbatches are available:

- Anti blocking agents
- Release agents
- UV stabilizers

## Use of Regrind

Depending on finished parts quality requirements, up to 30% of regrind can be recycled with virgin material. The material type and Shore hardness of the regrind should be identical to that of virgin Elastollan and has be free of contaminations.

Ideally, regrind should be diced, dried and re-used without intermediate storage.

Material which has been contaminated or degraded is not suitable for reprocessing.

Continuous recycling of regrind can lead to a reduction in the quality of finished parts. Certain quality requirements laid down in specifications may exclude the use of regrind material.

# General Recommendations

## Post-treatment

Moulded Elastollan parts require several weeks storage at room temperature to attain full mechanical properties. To achieve optimal functional properties in a shorter period, **annealing** of the finished parts is necessary. This heat treatment can be undertaken in a circulating-air oven.

Table 2 shows typical values for cured vs uncured Elastollan grades.

During annealing articles with low dimensional stability should be stored in such a way that deformation is avoided.

Extruded parts are annealed only in special cases.

### Annealing:

Recommended duration and temperature: 20 hours at 100 °C

Effect of curing on Elastollan properties						
Properties	Unit	DIN	Cured 20 h 100 °C	Uncured 20 h 23 °C	Uncured 7 d 23 °C	Uncured 35 d 23 °C
<b>Elastollan C 90 A 55</b>						
Hardness	Shore A	53505	91	91	92	92
Tensile strength	MPa	53504	48	42	44	46
Elongation	%	53504	580	570	550	500
Tear strength	N/mm	53515	98	80	83	85
Abrasion	mm <sup>3</sup>	53516	22	54	30	29
Compression set at 70 °	%	53517	33	60	53	50
<b>Elastollan C 1190 A 55</b>						
Hardness	Shore A	53505	90	89	91	91
Tensile strength	MPa	53504	48	43	45	46
Elongation	%	53504	550	560	530	500
Tear strength	N/mm	53515	85	74	73	79
Abrasion	mm <sup>3</sup>	53516	19	48	34	27
Compression set at 70 °	%	53517	36	70	65	65
Table 2						

# General Recommendations

## Health & Safety at Work

Depending on the grade used, Elastollan can be processed and machined over a wide range of temperature.

As with all natural or synthetic organic substances, decomposition is possible above certain temperatures. The rate of decomposition will depend on the temperature applied and the grade of material used.

Basically, onset of decomposition can be expected from temperatures of around 230°C upwards. Where elastomer melts emerge to the air, there is a possibility that the vapours released under such conditions will affect the workplace.

For this reason, an effective extraction system, especially in the melt outlet zone, is recommended.

## Disposal

Elastollan materials are fully reacted and present no hazard to the environment. Waste can therefore be disposed at public waste disposal sites or refuse incineration plants. The official regulations on waste disposal should be observed.

For further information see our safety data sheets.



# Processing Injection Moulding

## Machine Design

Screw injection moulding machines with single-flighted, 3-zone screws are suitable for the processing of Elastollan. Because of the high shear stress, short compression-zone screws are not suitable.

The following screw design has proven successful (see Fig. 4):

The compression ratio should be around 1:2 and should not exceed 1:3. The recommended flight depths are shown in Fig. 5.

A check ring (shut-off ring) should be incorporated. Both free flow and automatic shut off nozzles are suitable, although care should be taken to ensure smooth flow through the nozzle channels. Dead spots where the melt could accumulate and become charred should be avoided.

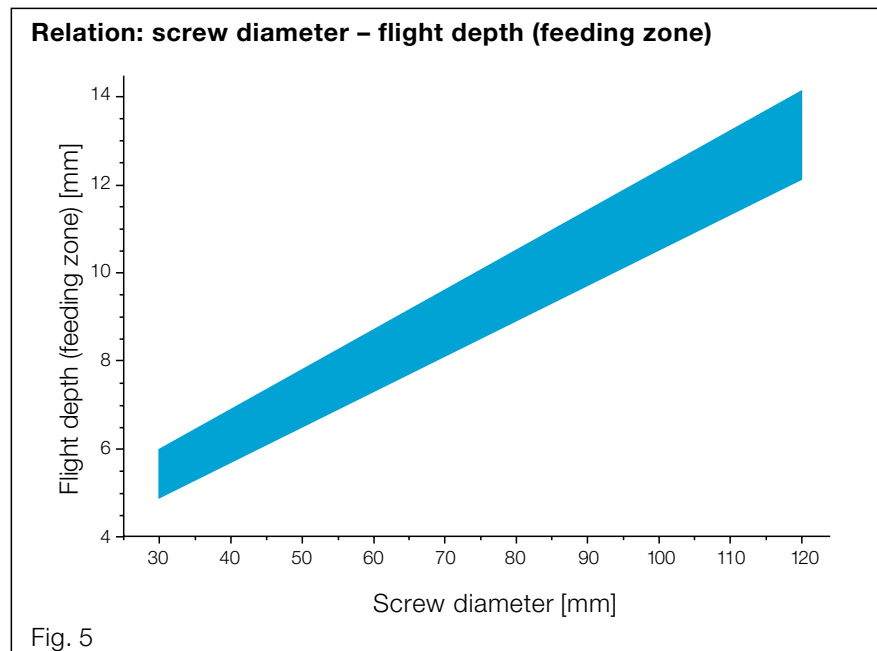
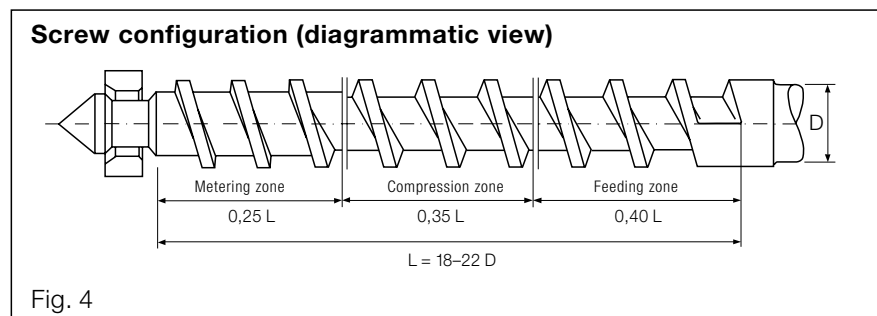

# Processing Injection Moulding

## Processing Parameters

To ensure trouble-free processing and consistently high quality moulded parts, precise and constant temperature control in the injection moulding cylinder is necessary.

The temperature should increase by roughly 10 to 20°C from the feeding zone to the metering zone. Nozzle temperature should be adjusted to suit the melt temperature.

Table 3 shows the recommended barrel temperatures for various ranges of hardness:

It is recommended to measure melt temperature and to adjust machine

temperature controllers accordingly (see table 4).

As Elastollan melts are shear-sensitive, excessive screw speed can cause reduced product properties.

Fig. 6 shows recommended screw speeds in relation to screw diameter.

Where cycles are interrupted for longer periods, the material remaining in the cylinder will become overheated. It is therefore necessary to purge out the cylinder before resuming production.

Recommended barrel temperatures in °C		
Shore hardness	Heating zone temperature	Nozzle temperature
60 A–80 A	170–210	200–210
85 A–95 A	190–220	210–225
98 A–74 D	210–230	220–240

Table 3

Recommended melt temperatures in °C	
Elastollan hardness 60 Shore A to 80 Shore A	190 to 205
Elastollan hardness 85 Shore A to 95 Shore A	205 to 220
Elastollan hardness 98 Shore A to 74 Shore D	215 to 235

Table 4

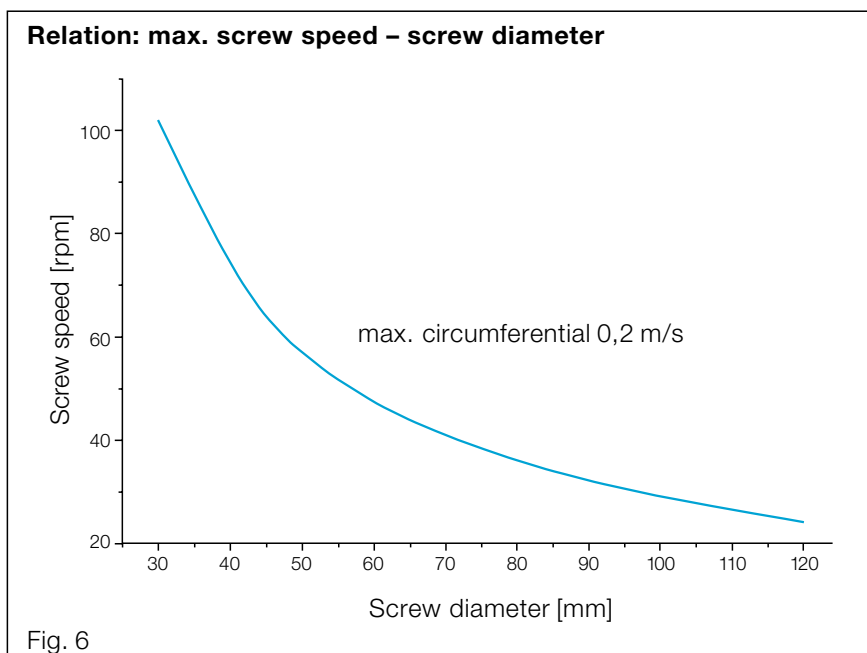

# Processing Injection Moulding

## Processing Parameters

### Cavity pressure pattern during processing

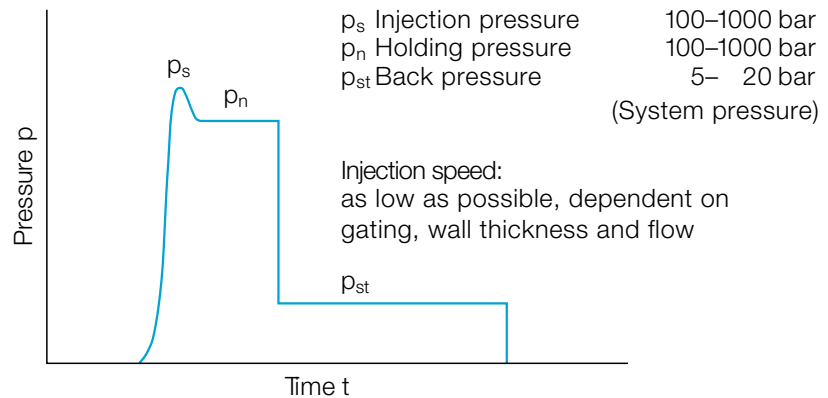

Fig. 7

The following machine parameters are especially important for the processing of Elastoflan (see Fig. 7):

#### Injection Pressure and Holding Pressure

These factors influence dimensional stability and ease of demoulding of the finished parts. If holding pressure is too low, sink marks may occur. If injection pressure is too high, then demoulding is more difficult.

#### Back Pressure

This effects the homogenization of the melt. It should not be set too high, owing to the shear sensitivity of the material.

#### Injection Speed

The correct injection speed is dependent on gating, wall section and flow. It should be kept as low as possible.

A typical cycle sequence for Elastollan is illustrated in diagrammatic form in Fig. 7.

#### Cycle Time

The cycle time depends on crystallisation-behaviour and demoulding characteristics. Demoulding time is determined primarily by mould temperature, wall section and hardness of the material.

Fig. 8 shows cycle time in relation to wall thickness for grades of different Shore hardness.

### Cycle time in relation to wall thickness

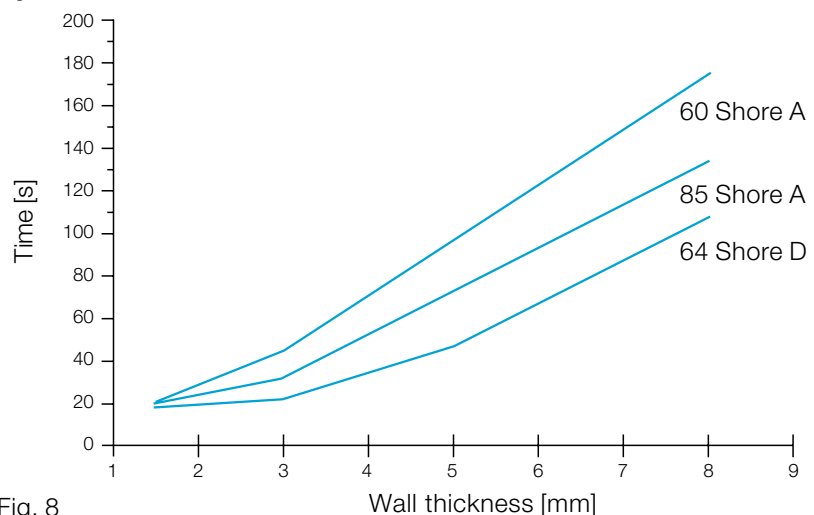

Fig. 8

# Processing Injection Moulding

## Mould Design

### Materials for Mould Construction

Materials commonly used for tools, like steel or steel alloys, are suitable for Elastollan mouldings. Moulds made from non-ferrous metals, mainly aluminium, are also working successfully; these cost-effective moulds are often used in footwear manufacture.

### Sprues

The maximum sprue diameter should not exceed the maximum wall thickness of the moulding. The diameter of the sprue cone should be adjusted to the nozzle and exceed the nozzle diameter by 0.5 mm. The gate should be located in the area of maximum wall thickness.

Sprue cones should be as short as possible and with a minimum angle of  $6^\circ$ . A sprue puller is advisable for easier demoulding.

### Runners

The melt properties of Elastollan require large diameter runners to avoid localized shearing and to enable the maximum pressure transfer to ensure mould filling.

For Elastollan, the best flow characteristics are achieved by using a **circular runner cross section**.

If **hot runners** are used preferably **external heated systems** should be selected. Internal heated systems are not suitable.

Multi-cavity tools need a balanced runner system.

### Runner systems

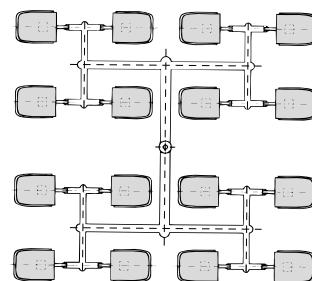

Fig. 9

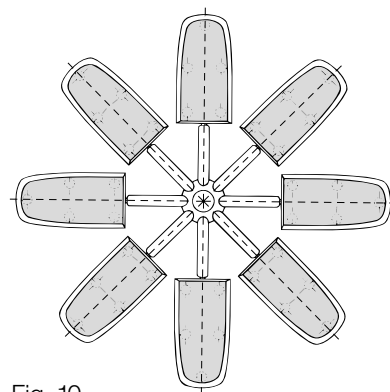

Fig. 10

### Gating

Gates for the processing of Elastollan should be large, to ensure adequate holding pressure and to avoid sink marks. Critical shear rate is  $25\,000\text{ s}^{-1}$ .

### Runner cross section

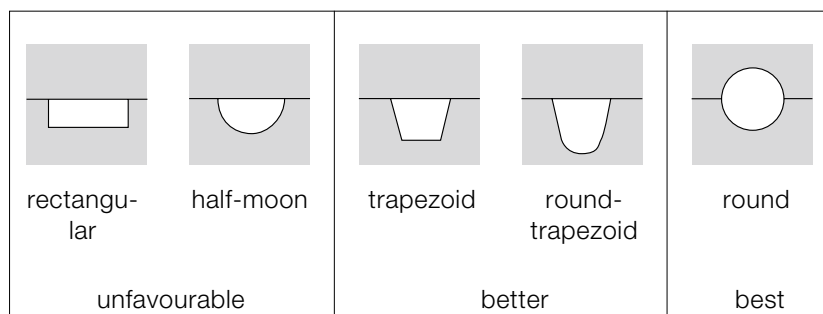

Fig. 11

# Processing Injection Moulding

## Mould Design

Designs commonly used include sprue, diaphragm, ring and film gates. Small parts may also be injected through pin gates.

Submarine gates are not recommended because of the high elasticity and possible shear degradation of the material. The softer Elastollan grades are especially prone to problems with this type of gate.

### Venting

Air must be able to escape easily from the mould cavities during injection of the melt, to prevent compressed air causing burn marks. Vent channels of 0.02 to 0.05 mm in depth are best located at the parting line, at inserts and at pins.

### Mould Surface

To facilitate demoulding, particularly when processing the softer Elastollan grades, mould surfaces with a roughness height of approx. 25 to 35  $\mu\text{m}$  are recommended.

Polished and chrome-plated mould surfaces are less suitable, since, especially with the softer grades, they promote sticking of the parts to the mould surface.

### Demoulding

The flexibility of Elastollan in the lower Shore hardness range allows quite large undercuts. Experience shows that short-term overstretching of less than 5% will not lead to permanent deformation.

For trouble-free demoulding, ejectors should be two to three times larger than for harder thermoplastics. They should be provided with venting channels, to prevent vacuum during demoulding.

### Mould Temperature Control

A good mould temperature control system is essential for production of high-quality mouldings. Mould temperature has an influence on surface quality, shrinkage and distortion.

### Recommended types of gate for Elastollan

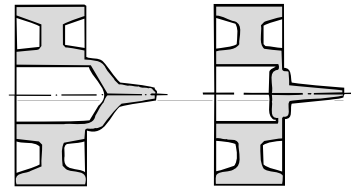

**Ring gate**

Fig. 12

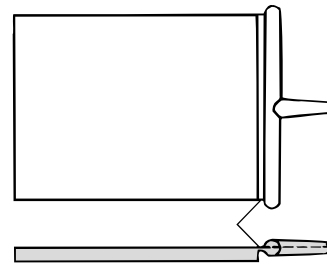

**Film gate**

Fig. 13

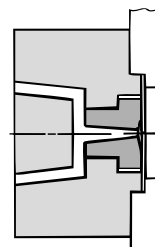

**Sprue gate**

Fig. 14

Mould temperatures may vary from 15 to 70°C, depending on the Elastollan grade and type of moulding.

Possible distortion of the moulded parts can be avoided by varying the temperature in each half of the mould.

# Processing Injection Moulding

## Shrinkage

The shrinkage of Elastollan mouldings is influenced by the following parameters:

- part design
- wall thickness
- gate design
- processing conditions, in particular melt temperature, injection pressure, holding pressure, mould temperature.

Total shrinkage is a result of moulding shrinkage and post-shrinkage which occurs not only during annealing, but also during longer-time storage of the parts.

For this reason it is difficult to predict shrinkage with any great accuracy.

Fig. 15 shows total shrinkage for unreinforced Elastollan grades in relation to wall thickness and Shore hardness.

Depending on glass fibre content glass fibre reinforced Elastollan grades show shrinkage of 0.05 to 0.20% in flow direction and of 0.1 to 0.5% transversal to flow direction.

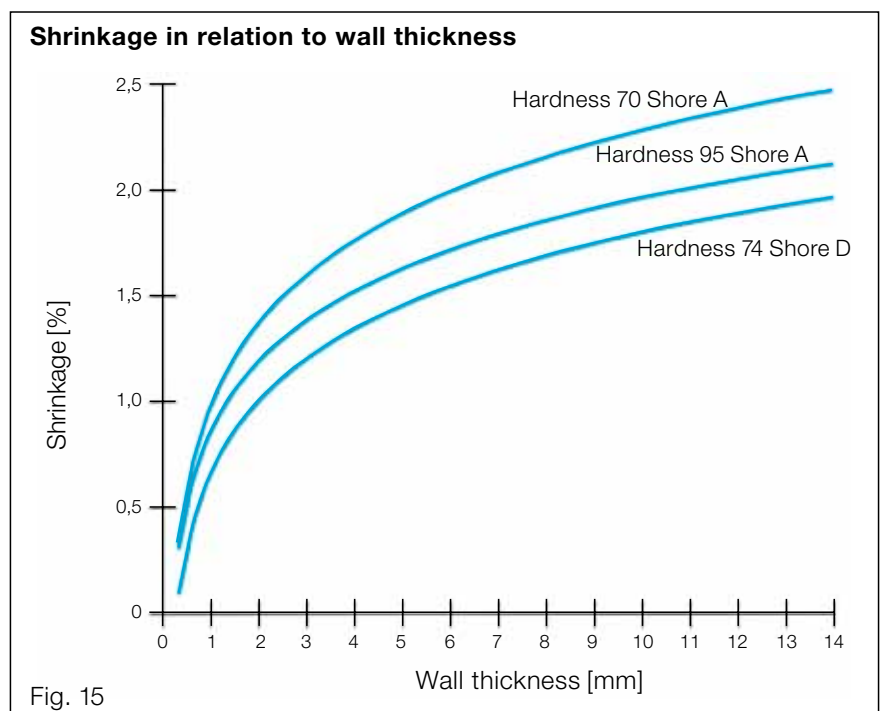

## Inserts

Inserts can be moulded-in without difficulty. However, for this purpose, Elastollan grades without lubricant are preferred.

Metal inserts must be free from grease, and should have features for mechanical anchorage, such as holes, undercuts, knurled grooves or notches.

Bonding may be further improved by the use of primers.

It is helpful to temper the inserts.

# Processing Injection Moulding

## Special Processing Methods

Following methods are suitable to combine other thermoplastic materials with Elastollan:

### Multicomponent Injection Moulding

Injection moulding of Elastollan and compatible plastic materials on multicomponent machines creates good bonding without using additives and mechanical anchorage. Polyolefin based materials are incompatible with Elastollan.

### Sandwich Injection Moulding

This is a special method of multicomponent injection moulding where a core component is combined with a different plastic material as outer

layer. Besides the combination of different thermoplastics it is possible to use regrind as core component and virgin grades as outer skin.

### Gas Injection Moulding

It is in principle similar to sandwich moulding. Gas is injected as core component for weight reduction.

## Trouble Shooting Guidelines

Trouble shooting guidelines														
	Melt temperature	Mould temperature	Injection speed	Holding pressure/time	Back pressure	Shot size/Melt cushion	Clamping pressure	Cooling time	Venting	Moisture content	Material contamination	Gate size	Lubricant	Residence time
Contamination											▼			▼
Bubbles/Blisters	▼		▼	▲	▲				▲	▼		▲	▼	▼
Burned spots	●	●	▼						▲	▼		▲		
Distortion/Shrinkage	●	●	●	●				●				▲		
Flow lines	●	●	●						▲	▼		▲		
Gloss/Matt surface	●	●	●	●					▲	▼		▲	●	
Flashing	▼	▼	▼	●			▲			▼		▲		
Short shot	▲	▲	▲	▲		▲			▲			▲		
Sink marks	●	●	●	▲		▲			▲	▼		▲		
Splay marks	▼	●	●						▲	▼		▲	▼	▼
Demoulding	●	●		●				●		▼		▲	▲	
Material degradation	▼		▼		▼					▼		▲		▼
▲ Increase to solve problem ▼ Reduce to solve problem ● Increase or reduce to solve problems														
Table 5														

# Processing Extrusion

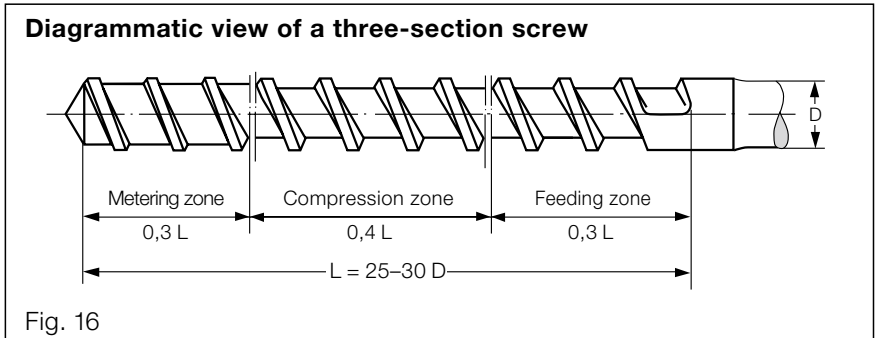

Fig. 16

Single-screw extruders with a compression ratio of 1:2 to 1:3, preferably 1:2.5, are recommended for processing of Elastollan.

Our experience shows that three section screws with a L/D ratio of 25 to 30 are most suitable.

Three-section screws should have a continuous, constant pitch of  $1D$ .

The radial clearance between screw and barrel should be 0.1 to 0.2 mm.

For processing of Elastollan multi-zone screws, e.g. barrier screws (undercuts  $\geq 1.2$  mm) have also proven suitable. Short screws with a high compression ratio are unsuitable.

Barrels with a grooved feeding zone have proven successful in practice, and provide the following benefits:

- constant feeding characteristics
- improved pressure build-up
- increased output

If grooved feeding zones are used, cooling is necessary. It is also advisable to use a screw with a mixing section, in order to improve homogeneity of the melt. Such mixing sections should, however, be designed to avoid shear degradation.

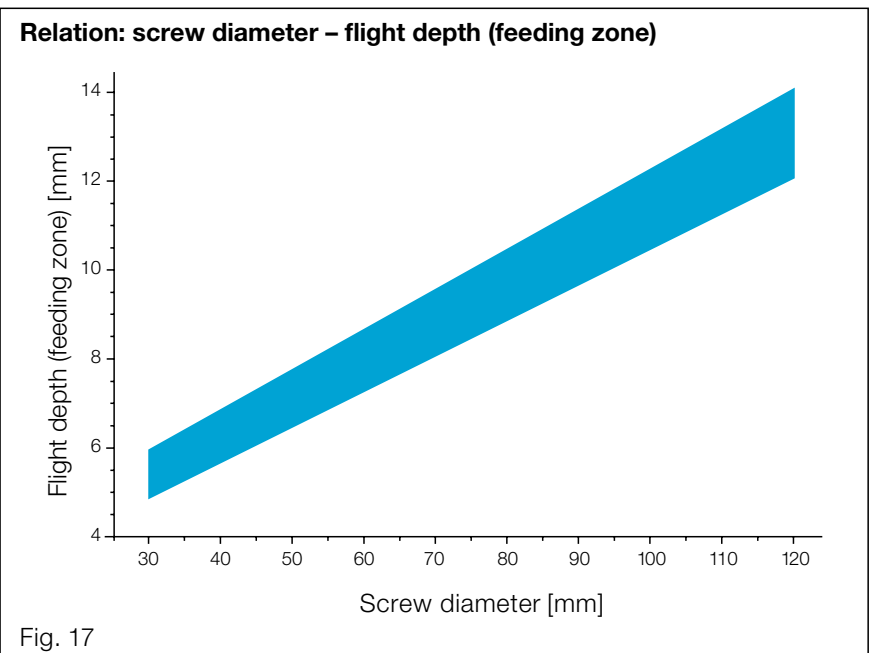

Fig. 17



# Processing Extrusion

## Machine Design

Use of breaker plates and screen packs is recommended. Good results have been obtained from a combination of two screens of 400 mesh/cm<sup>2</sup> as backing plates and two fine screens of 900 mesh/cm<sup>2</sup>. Finer screens may be necessary for certain applications (e.g. film production).

Depending on screw diameter and type of die, breaker plates should have holes of 1.5 to 5 mm in diameter.

Extrusion of thermoplastic polyurethane requires **a more powerful motor** than for other thermoplastics. Power consumption is between 0.3 and 1 kWh per kg output, depending on screw design.

Melt pumps have proved successful for continuous melt flow.

## Processing Parameters

### Processing Temperature

The following temperature ranges, which are dependent on the hardness of the Elastollan grades are recommended:

### Screw Speed

Since thermoplastic polyurethanes are shear-sensitive, excessively high screw speeds may lead to a reduction in product properties.

Fig. 18 shows the relation of max. screw speed to screw diameter.

Recommended temperatures for processing in °C				
Shore hardness	Cylinder	Heating zones		
		Adapter	Die head	Nozzle
60 to 70 A	140–175	160–175	165–170	160–165
75 to 85 A	160–200	175–200	175–205	170–205
90 to 98 A	170–210	200–220	195–215	190–210

Table 6

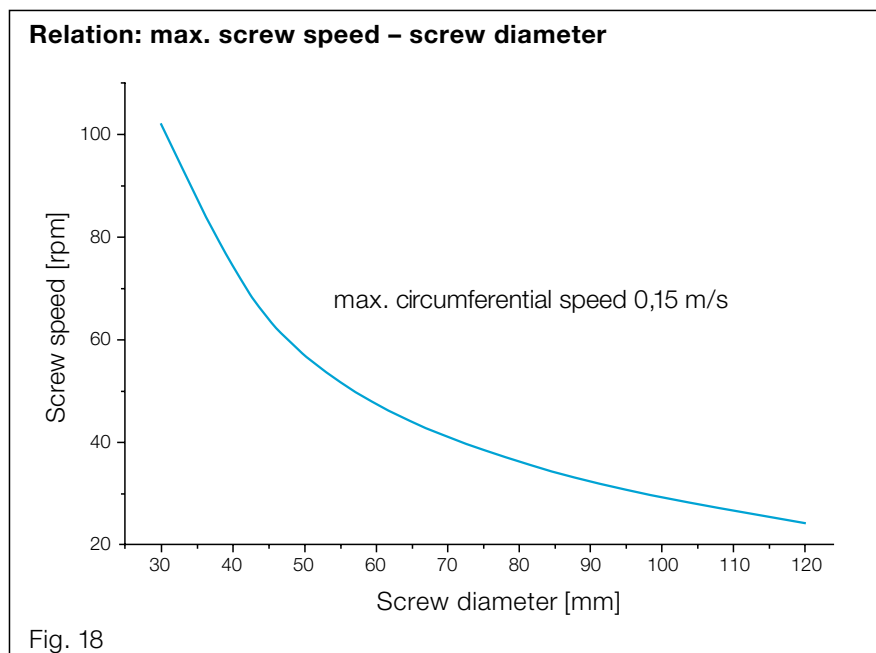

# Processing Extrusion

## Processing Parameters

### Melt Pressure

Melt pressure is dependent on the head-design and the die gap, and on melt temperature. Normally the maximum pressure at the adapter is 300 bar, however, peaks of up to 1.000 bar can occur at start-up. Thus, for safety at start-up, a variable screw drive is recommended. If needed, starve feeding is possible.

### Cleaning of the Extruder

When changing grade or after several days of continuous operation, cleaning of the extruder is recommended.

Polypropylene or HDPE, which require higher processing temperatures, are suitable for this purpose. In addition, it is sometimes necessary to use a purging compound.

## Die Design

To ensure a constant melt flow, it is important to operate with narrow cross-sections and to avoid dead spots in the die. This will cause automatic self-cleaning of the die.

In all other respects, guidelines for head design are the same as for the extrusion of other thermoplastics.

Fig. 19 shows examples of typical dies:

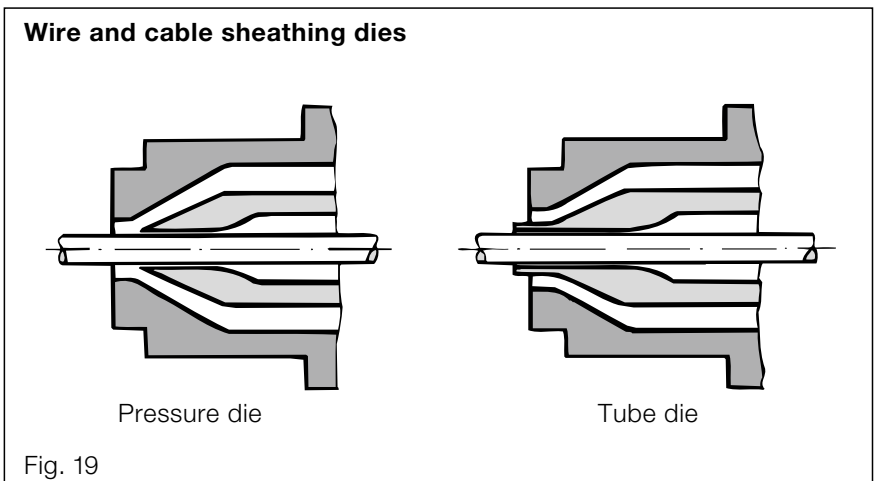

# Processing Extrusion

## Die Design

For extrusion of tubes and profiles, dies with a relatively long land are recommended. This reduces the shear stresses, thus permitting a

constant discharge. Land length should be two to four times nozzle diameter.

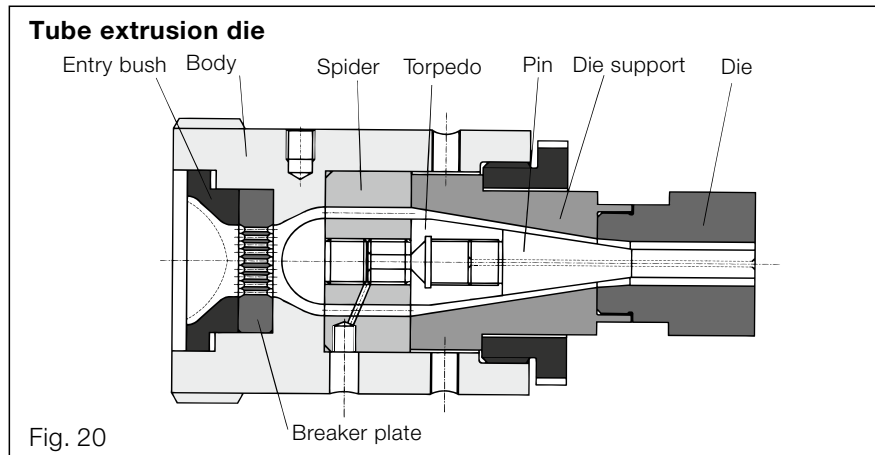

## Cooling and Calibration

Freshly extruded thermoplastic polyurethanes have a relatively low melt strength and are therefore prone to distortion. This necessitates effective cooling. The water bath should be close up to the extruder head. Chilled water is preferred. Instead of cooling baths a cooling line with spray nozzles is also suitable.

Calibration devices as shown in diagrammatic view in Fig. 21 are suitable to support the extrudate.

It is essential to provide a lubricating film of water between the surface of the extrudate and the calibrating die. This can be achieved by a water spray ring located before the entry into the cooling bath.

The length of cooling bath required for Elastollan grades generally exceeds the requirement for other thermoplastics. The length depends on the grade of material, extrudate shape and section, and haul-off speed.

Fig. 22 describes the layout of a tube extrusion line for Elastollan.

Due to high coefficient of friction, compared to general thermoplastics, active calibration of thermoplastic polyurethane is not possible.

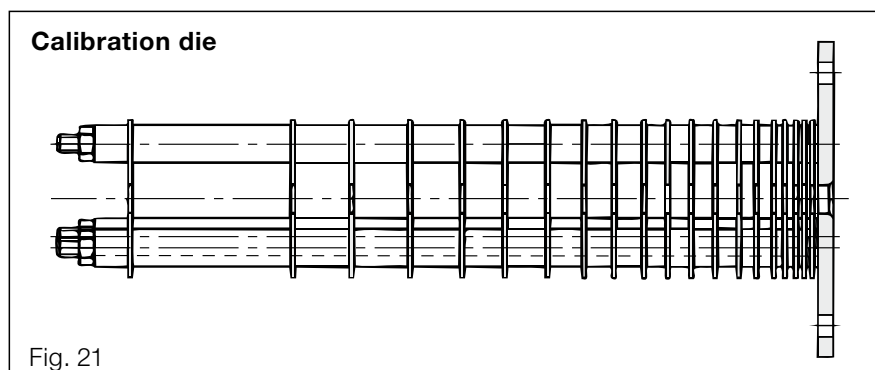

# Processing Extrusion

## Cooling and Calibration

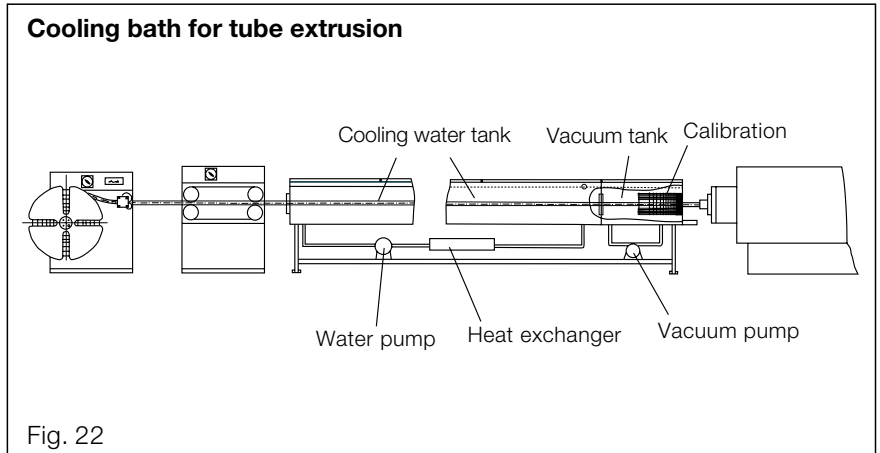

## Extrusion techniques

### Tubes and Profiles

Tubes and profiles are mostly extruded horizontally. However, thin-walled tubes, e.g. fire-hose linings, are generally extruded vertically.

It is necessary to supply supporting air to prevent collapsing of the tubes.

To assist shape stability for hollow shapes it is recommended to use vacuum.

The guide rollers in the cooling bath should be matched to the shape of the extrudate.

### Sheathing

Sheathing of cables, hoses, etc. is carried out by using a crosshead (see Fig. 23), equipped with a pressure or tube die (see Fig. 19). The inner-core which is to be sheathed must be dry and free from grease, in order to avoid blistering after extrusion and to ensure good bonding.

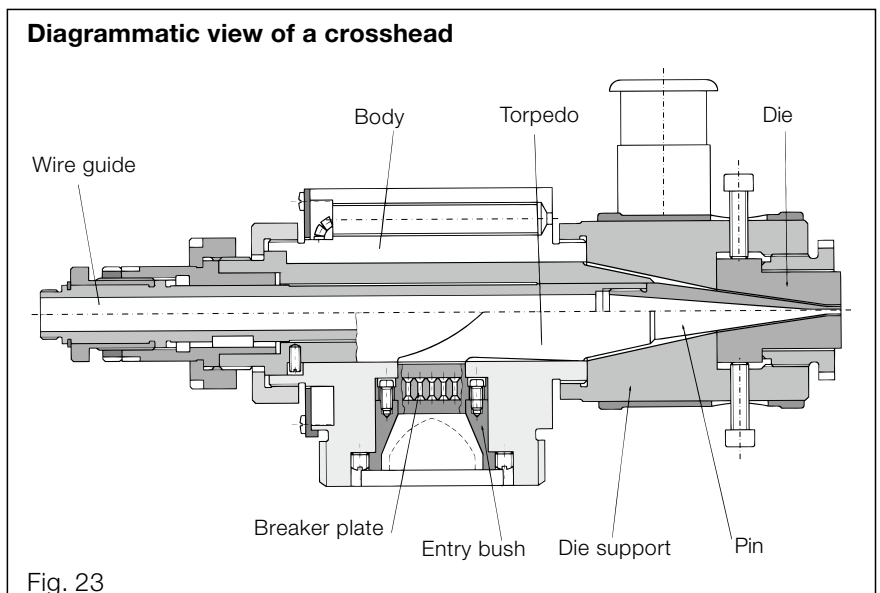

# Processing Extrusion

## Extrusion Techniques

### Film

Special Elastollan grades are suitable for the manufacture of blown film.

Fig. 24 shows, in diagrammatic form, a film blowing head.

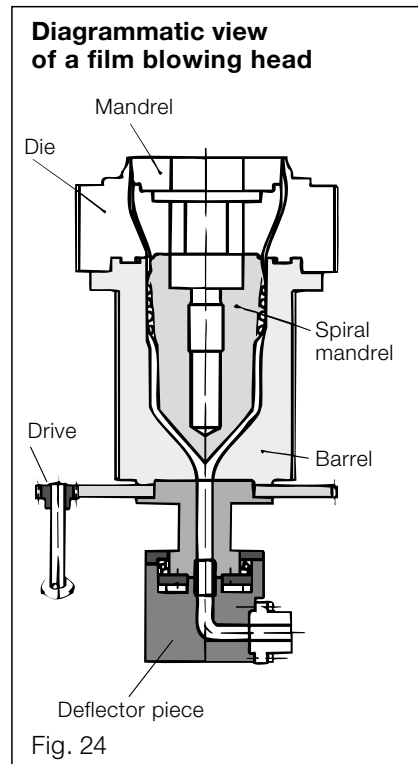

Films of greater wall thickness can be produced by the flat film extrusion process using a sheet die (see Fig. 25); normal extrusion grades are suitable.

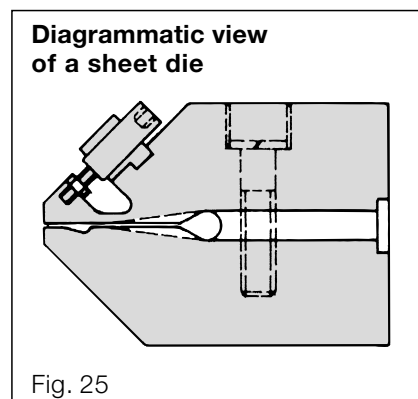

### Blow moulding

Blow moulded articles can be manufactured from selected Elastollan grades using conventional blow moulding machines.

To improve ease of demoulding, the use of a mould with roughened surface (approx.  $35\ \mu\text{m}$ ) is recommended. Wall thickness control is necessary to compensate for elongation of the parison. Fig. 26 shows a torpedo head for blow moulding.

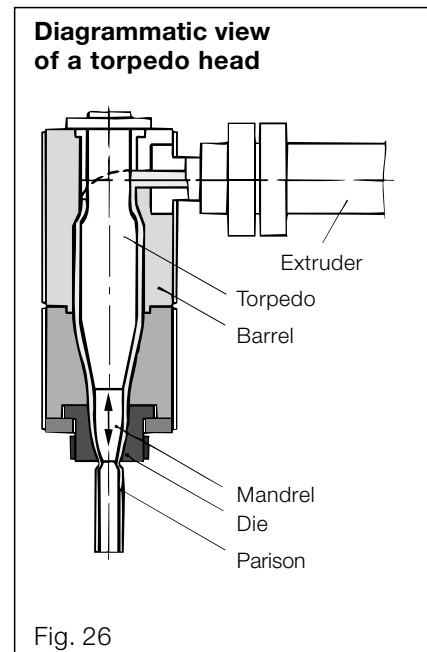

# Processing Extrusion

## Special Processing Methods

Following special methods are suitable for Elastollan:

### Coextrusion

to achieve a combination of properties of different thermoplastics in one processing step.

For bonding reasons materials have to be compatible. Compatibility can differ between Elastollan ether and ester types.

**Thermoplastic Foam Extrusion** for weight reduction and to achieve special properties.

Two methods are applicable:

- **Chemical expanding** of the melt by addition of expanding agent with conventional extruders; foam density between 0.4 and 1.0 g/cm<sup>3</sup> is attainable.
- **Physical expanding** of melt by injection of gas into the extruder. Foam density below 0.4 g/cm<sup>3</sup> is attainable. The structure of foam is controlled by a nucleating agent.

## Trouble Shooting Guidelines

Trouble shooting guidelines										
	Melt/ Cylinder tempera- ture	Die tempera- ture	Die pressure	Screw speed/ Output	Land length	Homo- genisation	Moisture content	Material contami- nation	Cooling feeding zone	Lubricant
Pulsation	●		●	▼		●	▼		●	▼
Rough surface	▲	▲		●	●	▲				▲
Surface streaks	▼	▼			●	▲	▼			●
Bubbles/Blisters	▼	▼	▲	▲			▼		▼	▼
Flow lines/ Spider lines	●		●	▼		▲	▼			
Excssive blocking	▼	▼	▲	▼			▼			▲
Unmelted particles	▲	▲		▼		▲		▼		
Dimensional variations	●	●	●	●	●	●	▼		●	▼
Unsufficient dimensional stability	▼	▼	▲	▼	●		▼			
Melt fracture	▲	▲	▼	●	●	●				▲
Material degradation	▼			●		▼	▼			
▲ Increase to solve problem ▼ Reduce to solve problem ● Increase or reduce to solve problems										
Table 7										

# Machining

## Welding

The following welding techniques have proved successful for the bonding of finished and semi-finished Elastollan parts:

*Injection moulded parts* are mainly bonded by **hot plate, ultrasonic** (harder types), **high frequency-** or **friction welding**.

For *semi-finished parts* and *profiles* **hot plate-** or **friction welding** is used as well as hot gas welding.

For *films* best results are achieved by **thermal sealing, heat impulse welding** or **high frequency welding**.

Decisive for the **weld strength** are: the **temperature** which enables below decomposition temperature a sufficient flow of Elastollan, and the **pressure** which generates the melt flow and sealing of the two layers. The pressure also provides stabilisation of the welding joint during setting time.

In all welding operations, provision must be made for the extraction of gases (see page 8, Health & Safety at Work).

## Bonding

In order to facilitate bonding it is recommended to use Elastollan grades without lubricant. Polyurethane based elastic adhesives have proved successful in the bonding of Elastollan parts. Epoxy resin adhesive are used for bonding to metals and other hard materials.

Adhesives manufacturers offer suitable systems for this purpose.

The usual preparatory work should be undertaken before bonding.

## Surface Finishing

Printing and painting are possible when lubricant-free Elastollan grades are used.

Suitable printing and painting systems are offered by paint and dye manufacturers.

# Machining

## Machining Parameters

Owing to the exceptional toughness and tear strength of Elastollan, machining is not without problems, and much depends on the hardness of the material to be machined. With all tools used for machining Elastollan, care should be taken to ensure that cutting edges are correctly sharpened.

In machining Elastollan, excessive generation of heat should be avoided. Accordingly, always provide for cooling by compressed air or emulsion.

The following table gives recommended values for machining Elastollan:

Parameters for machining Elastollan				
	Turning	Milling	Drilling	Grinding
Clearance angle $\alpha$ [°]	6–15	~ 10	12–16	/
Rake angle $\gamma$	up to 25	15–25	10	/
Setting angle $\chi$ [°]	45–60	/	/	/
Point angle $\delta$ [°]	/	/	80	/
Cutting speed	100–500	200–500	40–50	30–50 m/s
Rate of advance	0.1–0.4 mm/r	20–200 mm/min.	0.01–0.04 mm/r	max. $\frac{2}{3}$ of grinding wheel width per tool rotation
Depth of cut $a$ [mm]	à 15	2–8	/	0.1–3
Centre radius $r$ [mm]	~ 0.5			
Tool	HSS, SS, HM	HSS, SS, HM		
<b>Drilling:</b> Hollow drill, twist drill, tooth face-milling cutter				
<b>Grinding:</b> Grinding wheel with open structure and low hardness; high porous type (grain size 60 -80):				
Table 8				

## Drilling

Drilled holes generally turn out to be smaller than the nominal diameter of the drill. For qualities up to 80 Shore A, the reduction in diameter is around 4–5%. As a rule, hollow drills produce holes with greater dimensional accuracy.

During drilling efficient cooling is recommended and the drill should be lifted frequently.



# Machining

## Turning

In order to reduce cutting forces and heat, tools used for turning should have smaller-diameter cutters than those used for metal.

## Milling

Conventional milling machines and manual milling cutters may be used for Elastollan. Where cutter heads are used, in order to ensure good chip formation, the number of blades should be kept to a minimum.

## Cutting

Cutting blades with close pitch and large setting are suitable.

## Grinding

Elastollan parts may be ground.

Grinding wheels should not be too wide to prevent overheating at the grinding point (max. 20 mm). Cooling is advantageous and will permit a higher grinding speed.

## Punching

The shape of the stamped surface will depend on material hardness. Fig. 27 shows the results of stamping of soft and hard Elastollan types.

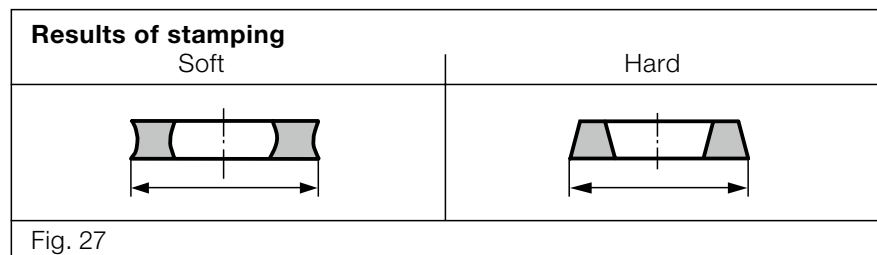

# Quality Management

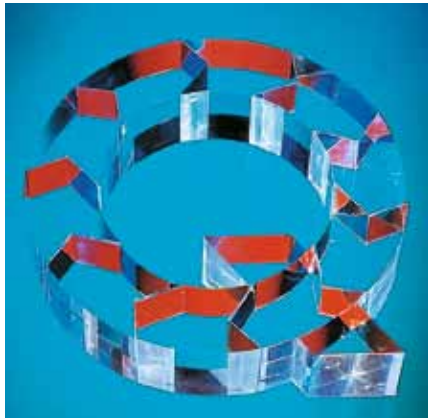

## Quality Guidelines

- The orientation on customers processes and on employees are important elements of the Quality Management.
- The customer requirements are determined regularly and fulfilled with the aim of the increase of the customer satisfaction.
- Targets are agreed with the persons responsible for process in all units of competence and the realization is followed regularly.
- Targets, methods and results of the Quality Management are continually imparted in order to support the consciousness and the cooperation of all employees in the process of the continuous quality improvement.
- Instead of later debugging, the principle of avoidance of defects is realized.
- Organizational and personnel measures will be concentrated on effective quality management to ensure the implementation of the quality targets.

## Management-Systems / Certificates

Customer satisfaction is the basis for sustained business success. Therefore, we want to meet the customers' requirements for our products and services, now and for long-term future. To ensure success in a reliable way, BASF Polyurethanes Europe introduced a quality management system several years ago including all divisions. Each business process is regularly assessed and further developed based on informative performance indicators. The target is to reach optimum efficiency and almost perfect coordination of all activities and operations. Each employee is asked to make a contribution to quality assurance and continuous improvement with its capabilities and ideas at its workplace.

Our integrated Quality and Environmental Management-System is based on following standards:

DIN EN ISO 9001

ISO/TS 16949 (with product development)

DIN EN ISO 14 001 (environmental management system)

# Index of Key Terms

## A

Additives \_\_\_\_\_ 6  
Annealing \_\_\_\_\_ 7

## B

Back pressure \_\_\_\_\_ 11  
Blow moulding \_\_\_\_\_ 21  
Bonding \_\_\_\_\_ 23

## C

Calibration \_\_\_\_\_ 19, 20  
Circulating air oven \_\_\_\_\_ 5  
Coextrusion \_\_\_\_\_ 22  
Colouring \_\_\_\_\_ 6  
Cooling \_\_\_\_\_ 19, 20  
Cutting \_\_\_\_\_ 25  
Cycle time \_\_\_\_\_ 11

## D

Demoulding \_\_\_\_\_ 13  
Disposal \_\_\_\_\_ 8  
Drilling \_\_\_\_\_ 24  
Drying  
– driers \_\_\_\_\_ 5  
– drying parameters \_\_\_\_\_ 5  
– water content \_\_\_\_\_ 5

## E

Extrusion  
– calibration \_\_\_\_\_ 19, 20  
– cooling \_\_\_\_\_ 19, 20  
– die design \_\_\_\_\_ 18, 19  
– machine design \_\_\_\_\_ 16, 17  
– processing \_\_\_\_\_ 17, 18  
Extrusion techniques  
– blow moulding \_\_\_\_\_ 21  
– film \_\_\_\_\_ 21  
– profiles \_\_\_\_\_ 20  
– tubes/hoses \_\_\_\_\_ 20  
– sheathing \_\_\_\_\_ 20

## F

Film gate \_\_\_\_\_ 13  
Film production \_\_\_\_\_ 21  
Flight depth \_\_\_\_\_ 8, 16

## G

Gas injection moulding \_\_\_\_\_ 15  
Gating \_\_\_\_\_ 11  
Grinding \_\_\_\_\_ 25

## H

Health and Safety at work \_\_\_\_\_ 8  
Holding pressure \_\_\_\_\_ 11  
Hygroscopicity \_\_\_\_\_ 4

## I

Injection moulding  
– machine design \_\_\_\_\_ 9  
– mould design \_\_\_\_\_ 12, 13  
– processing \_\_\_\_\_ 10, 11  
– shrinkage \_\_\_\_\_ 14  
Injection pressure \_\_\_\_\_ 11  
Injection speed \_\_\_\_\_ 11  
Inserts \_\_\_\_\_ 14

## M

Machine design  
– extrusion \_\_\_\_\_ 16, 17  
– injection moulding \_\_\_\_\_ 9  
Machining \_\_\_\_\_ 23, 24, 25  
Milling \_\_\_\_\_ 25  
Moisture absorption \_\_\_\_\_ 4  
Mould design  
– extrusion \_\_\_\_\_ 18, 19  
– injection moulding \_\_\_\_\_ 12, 13  
Mould surface \_\_\_\_\_ 13  
Mould temperature \_\_\_\_\_ 13  
Multi-component  
injection moulding \_\_\_\_\_ 15

## P

Post-treatment \_\_\_\_\_ 7  
Processing  
– extrusion \_\_\_\_\_ 17, 18  
– injection moulding \_\_\_\_\_ 10, 11  
Profile extrusion \_\_\_\_\_ 20  
Punching \_\_\_\_\_ 25

## Q

Quality management \_\_\_\_\_ 26

## R

Ring gate \_\_\_\_\_ 13  
Runners \_\_\_\_\_ 12

## S

Sandwich moulding \_\_\_\_\_ 15  
Screw configuration  
– extrusion \_\_\_\_\_ 16  
– injection moulding \_\_\_\_\_ 9  
Screw flight depth  
– extrusion \_\_\_\_\_ 16  
– injection moulding \_\_\_\_\_ 9  
Screw speed  
– extrusion \_\_\_\_\_ 17  
– injection moulding \_\_\_\_\_ 10  
Sheathing/Cable sheathing \_\_\_\_\_ 20  
Shrinkage \_\_\_\_\_ 14  
Special processing methods  
– extrusion \_\_\_\_\_ 22  
– injection \_\_\_\_\_ 15  
Sprue \_\_\_\_\_ 12  
Sprue gate \_\_\_\_\_ 13  
Storage \_\_\_\_\_ 4  
Surface finishing \_\_\_\_\_ 23

## T

Temperatures  
– drying \_\_\_\_\_ 5  
– extrusion \_\_\_\_\_ 17  
– injection moulding \_\_\_\_\_ 10  
Thermoplastic foam extrusion \_\_\_\_\_ 22  
Trouble shooting guidelines  
– extrusion \_\_\_\_\_ 22  
– injection moulding \_\_\_\_\_ 15  
Tube/Hose production \_\_\_\_\_ 20  
Turning \_\_\_\_\_ 25

## U

Use of regrind \_\_\_\_\_ 6

## V

Venting \_\_\_\_\_ 13

## W

Water content \_\_\_\_\_ 5  
Welding \_\_\_\_\_ 23

## **BASF Polyurethanes GmbH**

With top quality products, a reputation for good customer service and continuous progress and development, Elastollan has secured a firm position in numerous markets.

We want to share our know-how and experience to contribute to your own success: The versatile Elastollan is the ideal material to fulfill your requirements.

For further information, the following detailed brochures are available upon request:

- Thermoplastic Polyurethane Elastomers: Elastollan
- Elastollan – Product Range
- Elastollan – Material Properties
- Elastollan – Electrical Properties
- Elastollan – Chemical Resistance

**BASF Polyurethanes GmbH**  
European Business Management  
Thermoplastic Polyurethanes  
Elastogranstraße 60  
49448 Lemförde  
Germany  
Telephone ++49 (54 43) 12-25 00  
Telefax ++49 (54 43) 12-25 55  
E-Mail [elastomere@basf.com](mailto:elastomere@basf.com)  
[www.pu.basf.eu](http://www.pu.basf.eu)

®= Registered Trademark of BASF Polyurethanes GmbH

The data contained in this publication are based on our current knowledge and experience. In view of the many factors that may affect processing and application of our product, these data do not relieve processors from carrying out their own investigations and tests; neither do these data imply any guarantee of certain properties, nor the suitability of the product for a specific purpose. Any descriptions, drawings, photographs, data, proportions, weights etc. given herein may change without prior information and do not constitute the agreed contractual quality of the product. It is the responsibility of the recipient of our products to ensure that any proprietary rights and existing laws and legislation are observed. (10/10)